

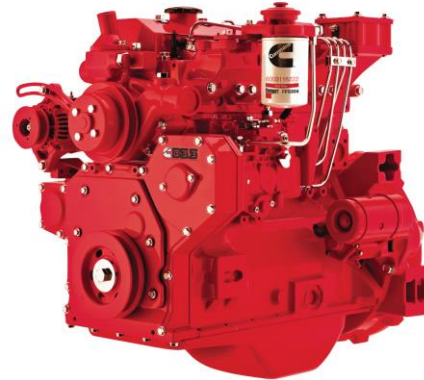

4BT3.3-G5

2g TA Luft Compliant



Description

The B3.3 has all the strength and reliability the genset industry has come to expect from the B Series range but in a smaller, lighter and more economical package. The B3.3 features indirect fuel injection, resulting in cleaner, quieter and more fuel efficient performance. With a highly compact 4 cylinder envelope and extremely low heatrejection, the engine offers a high degree of installation flexibility.



This engine has been designed in facilities certified to ISO9001 and manufactured in facilities certified to ISO9001 or ISO9002.

Features

Stanadyne Fuel Pump – Rotary fuel pump with indirect injection for cleaner, more efficient fuel consumption.

Parent Bore Block - Deep, stiff crankcase and optimised rib arrangement to enhance strength and reduce noise.

12 volt electrics package as standard, with starter, alternator and fuel solenoid.

Minimal derate for high altitude or high ambient applications.

Shallow oil pan and single spin-on oil filter.

SAE '4' flywheel housing.

Integrated Design - Each component has been specifically developed and rigorously tested for G-Drive products, ensuring high performance, durability and reliability.

Service and Support - G-Drive products are backed by an uncompromising level of technical support and after sales service, delivered through a world class service network.

1800 rpm (60 Hz ratings)

Gross engine output			Typical generator set output					
Standby	Prime	Base	Standby (ESP)		Prime (PRP)		Base (COP)	
kWm/BHP			kWe	kVA	kWe	kVA	kWe	kVA
51/69	45/60	41/55	40	50	36	45	30	38

General engine data

Type	4 cycle, in-line, turbocharged
Bore mm	95 mm (3.74 in.)
Stroke mm	115 mm (4.53 in.)
Displacement litre	3.3 litre (199 in. ³)
Cylinder block	Cast iron, 4 cylinder
Battery charging alternator	35 amps
Starting voltage	12 volt, negative ground
Fuel system	Indirect injection (IDI)
Fuel filter	Spin-on fuel filters with water separator
Lube oil filter type(s)	Spin-on full flow filter
Lube oil capacity (l)	7.9
Flywheel dimensions	4/11

Coolpac performance data

Cooling system design	Jacket water
Coolant ratio	50% ethylene glycol; 50% water
Coolant capacity (l)	4.6

Fuel consumption 1500 (50 Hz)

%	kWm	BHP	L/ph	g/kWh
Standby Power				
100	-	-	-	-
Prime Power				
100	-	-	-	-
75	-	-	-	-
50	-	-	-	-
25	-	-	-	-
Continuous Power				
100	-	-	-	-

Fuel consumption 1800 (60 Hz)

%	kWm	BHP	L/ph	g/kWh
Standby Power				
100	51	69	14	3.8
Prime Power				
100	45	60	13	3.4
75	34	45	10	197
50	22	30	7	200
25	11	15	4	221
Continuous Power				
100	244	327	12	198

Weights and dimensions

Length mm	Width mm	Height mm	Weight (dry) kg
838	611	902	265

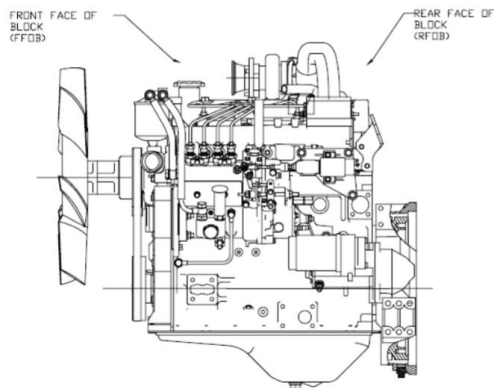

Ratings definitions

Emergency Standby Power (ESP):	Limited-Time Running Power (LTP):	Prime Power (PRP):	Base Load (Continuous) Power (COP):
Applicable for supplying power to varying electrical load for the duration of power interruption of a reliable utility source. Emergency Standby Power (ESP) is in accordance with ISO 8528. Fuel Stop power in accordance with ISO 3046, AS 2789, DIN 6271 and BS 5514.	Applicable for supplying power to a constant electrical load for limited hours. Limited-Time Running Power (LTP) is in accordance with ISO 8528.	Applicable for supplying power to varying electrical load for unlimited hours. Prime Power (PRP) is in accordance with ISO 8528. Ten percent overload capability is available in accordance with ISO 3046, AS 2789, DIN 6271 and BS 5514.	Applicable for supplying power continuously to a constant electrical load for unlimited hours. Continuous Power (COP) in accordance with ISO 8528, ISO 3046, AS 2789, DIN6271 and BS 5514.

For more information contact your local Cummins distributor or visit power.cummins.com

Our energy working for you.™

